

CHS2 Inverter Quick Installation Guide

For more information, refer to the inverter user manual.

1. Checking Installation Ways and Gaps

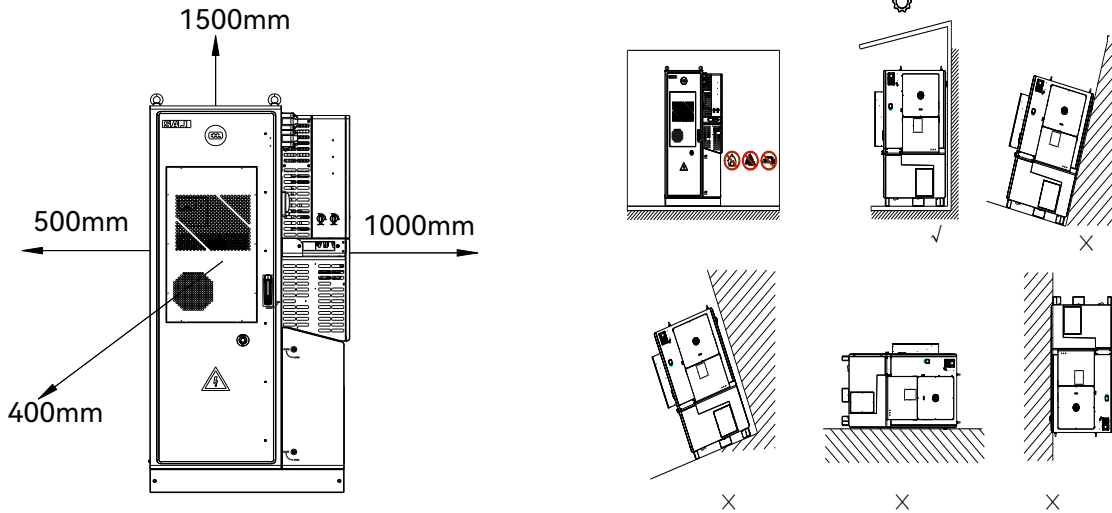

2. Installing the Inverter

1. Drill six holes (16mm in diameter, 50-55mm in depth) at the position marked by the measuring tape, Disassemble the M12*80 expansion screw and put the screw sleeve into the hole.

Note: The ground should be flat and no inclination.

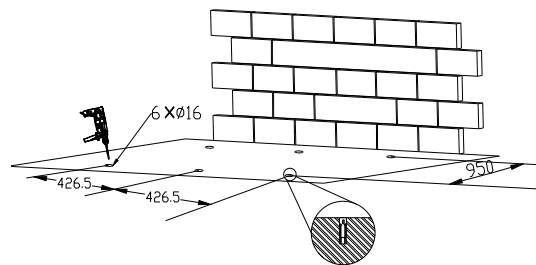

2. Transportation method

Crane handling:

Secure the eyebolts onto the top of the cabinet. Lift the cabinet and place it on the position of drilled holes. Moving this device requires a force greater than 2t, and the angle between the sling and the top surface must be greater than 60 degrees.

Forklift transportation:

Move the cabinet and place it over the drilled holes. Adjust the width of the forklift legs so that the center of gravity is in the center of the forklift legs. The forks should completely fit the bottom of the cabinet without damaging the cabinet. The forklift load capacity must be greater than 2 tons, and the fork depth must be greater than 1.2m.

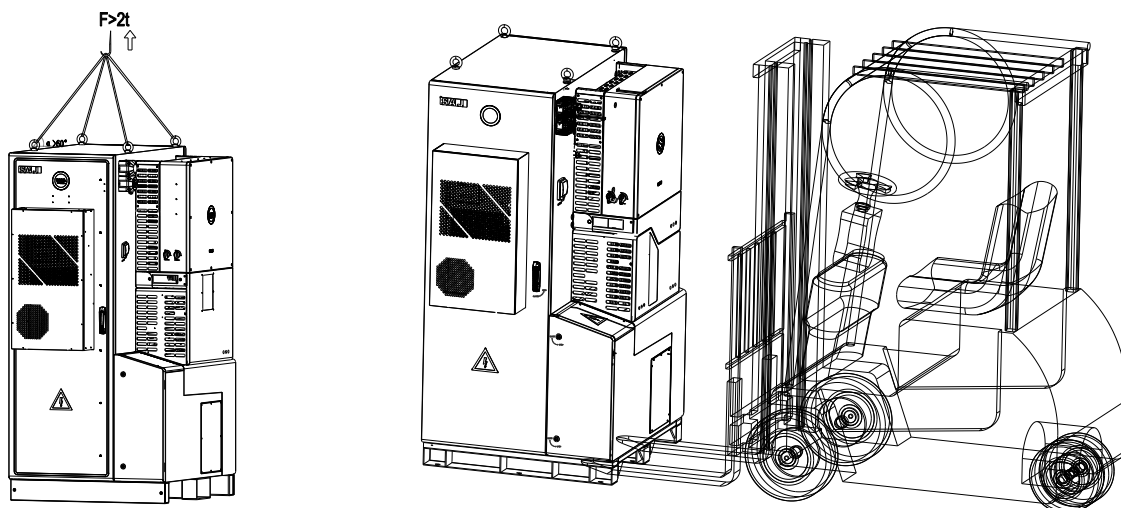

3. Use the wrench to secure the bottom with the expansion bolts (M12*80)

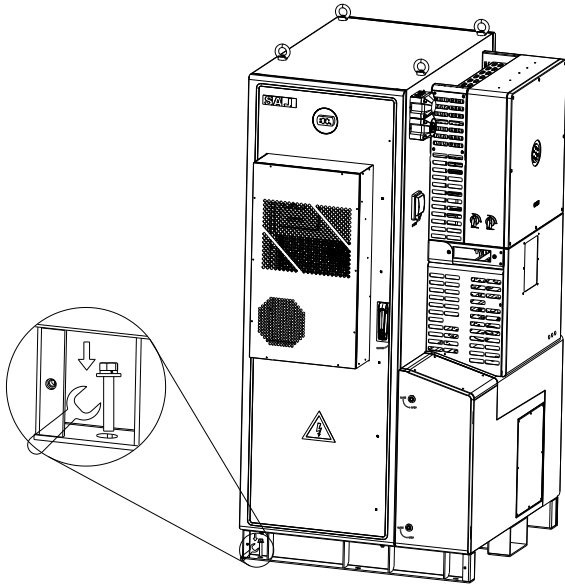

□ 3. Additional Grounding Protection

Note: A 6 mm² conductor cross-sectional area of cable is recommended for additional grounding cable.

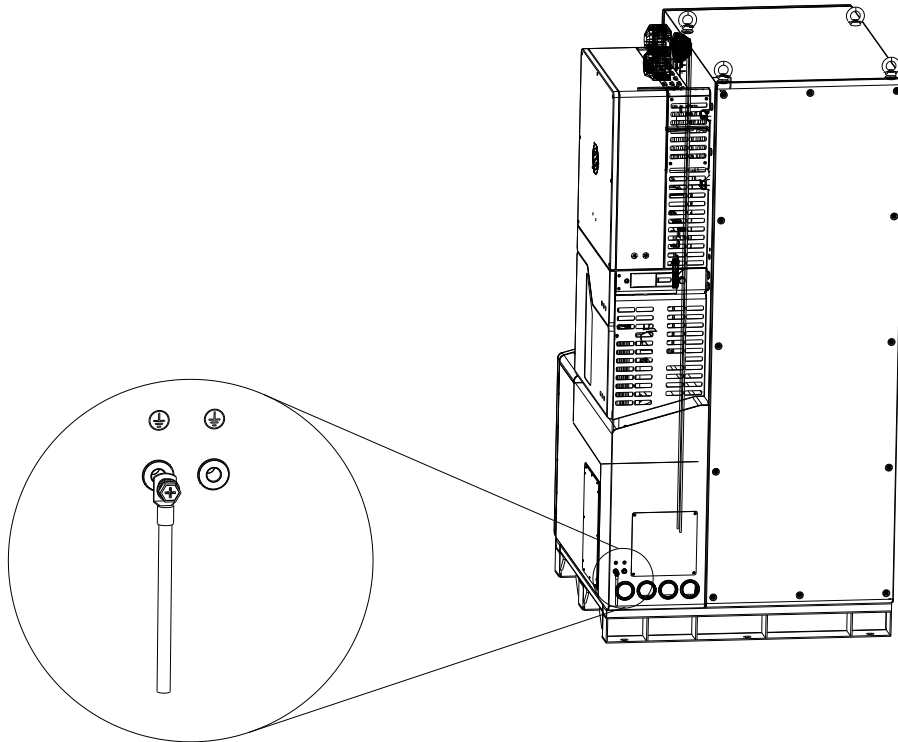

□ 4. Communication Connection

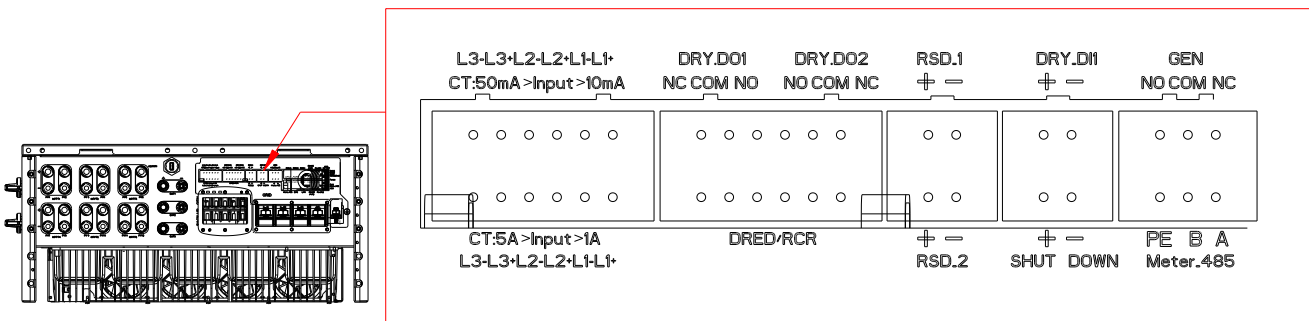

1. Remove the decorative panel and AC cover

Note: The machine and external wiring need to pass through the machine through the hole in the lower right corner of the machine.

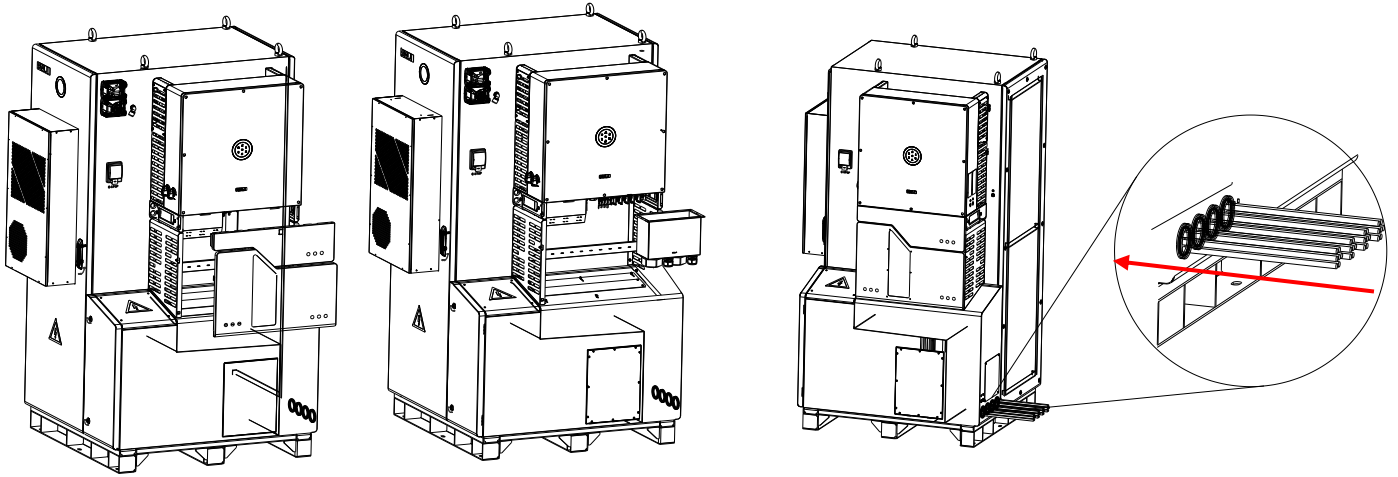

2. Grid Current Sampling

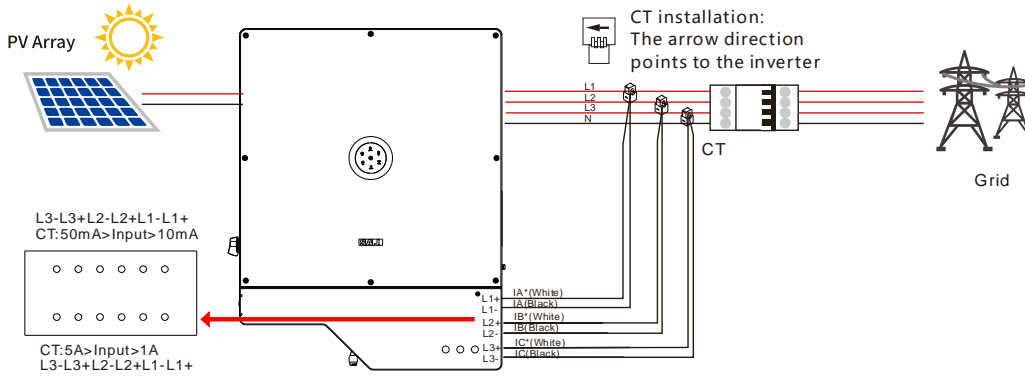

3. Dry Contact Connection

Reserved output dry contact:

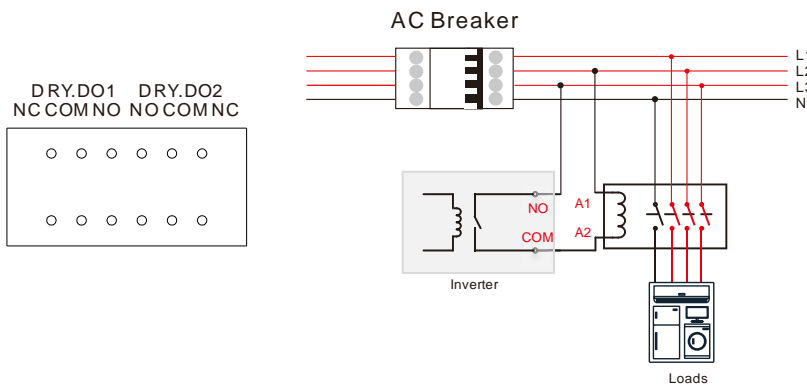

Generator start and stop control signal:

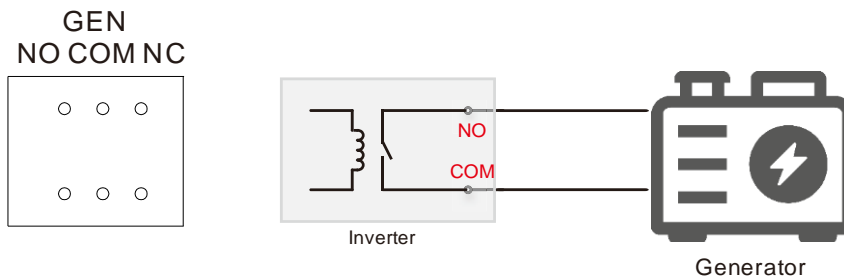

4. DRM Connection

DRED provides a DRED signal controlling port to meet the Australia DERD certification requirements and other regions.

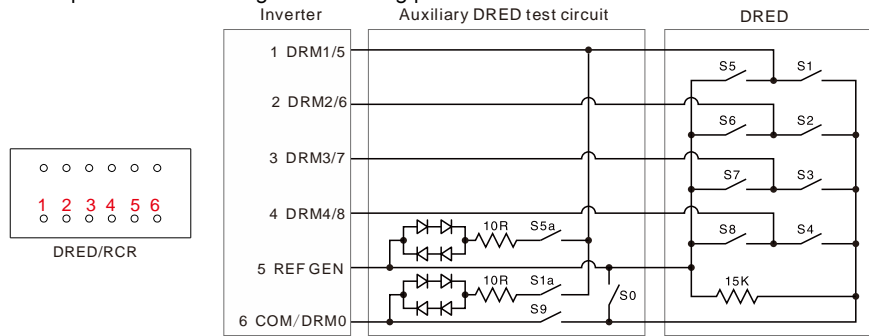

5. 12V Power Output

RSD_1, RSD_2 supplies power to the external photovoltaic fast shutdown module, and controls the power on and off by controlling the power of the module.

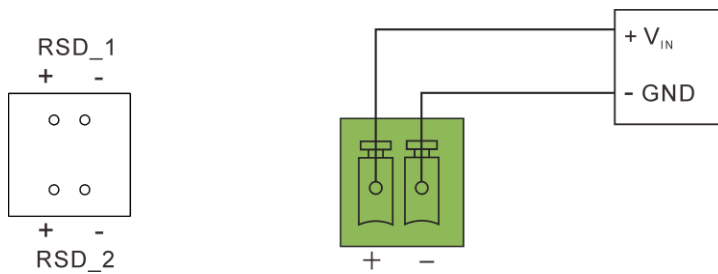

6. Emergency Stop Dry Contact

When + contact and - contact are shorted by external controlled switch, the inverter will stop immediately. DRY_DI1: Reserved input dry contact.

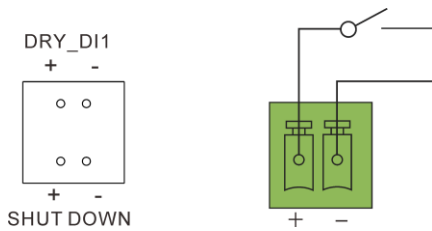

7. RJ45 Pin Port Definition



EMS	
1	NC
2	NC
3	NC
4	NC
5	NC
6	NC
7	RS485-A
8	RS485-B

RS485_PAR1/RS485_PAR2	
1	NC
2	NC
3	NC
4	NC
5	NC
6	NC
7	RS485-A
8	RS485-B

METER	
1	RS485-B
2	RS485-A
3	NC
4	RS485-B
5	RS485-A
6	NC
7	RS485-A
8	RS485-B

BMS_1/ BMS_2/ BMS_3	
1	Shut down—BMS
2	GND_S
3	NC
4	CANH
5	CANL
6	NC
7	NC
8	NC

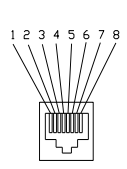

Parelle1/ Parelle2	
1	SYN B
2	SYN A
3	SYN B
4	SYN A
5	SYN B
6	SYN A
7	CANL
8	CANH

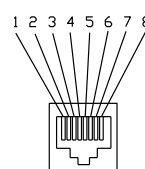

LAN	
1	TX_D1+
2	TX_D1-
3	RX_D2+
4	BL_D3+
5	BL_D3-
6	RX_D2-
7	BL_D4+
8	BL_D4-

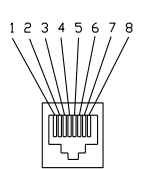

5. Connecting the AC Cable

Recommended specifications of GRID cables:

Type	Cable cross-sectional area (mm ²)		Conductor material
	Range	Recommend	
CHS2-29.9~63K-T4/T5/T6-X	25~35	25	Copper
Grounding cable cross-sectional area (mm ²): 16			

Recommended specifications of GEN and Back-up cables:

Type	Cable cross-sectional area (mm ²)		Conductor material
	Range	Recommend	
CHS2-29.9~63K-T4/T5/T6-X	16~25	16	Copper
Grounding cable cross-sectional area (mm ²):16			

Note: If the grid-connection distance is too far, please select an AC cable with larger diameter as per the actual condition.

1. Pass the cables to be connected through the corresponding waterproof holes.

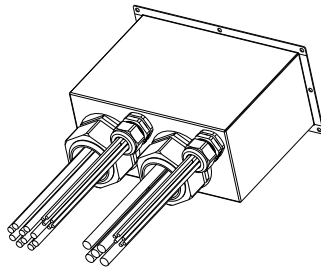

2. Connect the communication cable to the corresponding port. GRID, GEN and Back-up Fix the cables according to conductor marks of L1, L2, L3, N and PE.

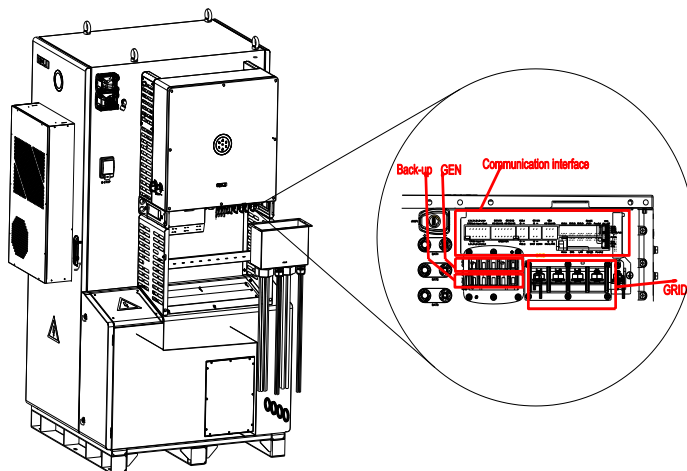

3. Secure all parts of the grid and backup connector tightly.
4. During off grid operation time, PE line at the BACK-UP end will remain to be connected with the PE line at the power grid end inside the inverter. (Only applicable to market in Australia)

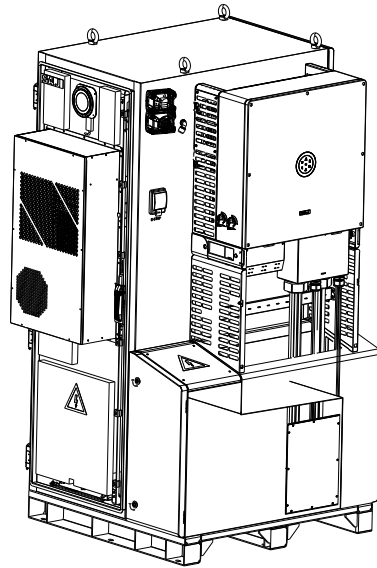

□ 6. PV Side Connection

Recommended specifications of DC cable

Conductor cross-sectional area of cables (mm ²)		Conductor material
Scope	Recommended value	Outdoor multi-core copper wire cable, complying with 1000Vdc
4.0~6.0	4.0	

1. Remove the upper cover of the PV cover

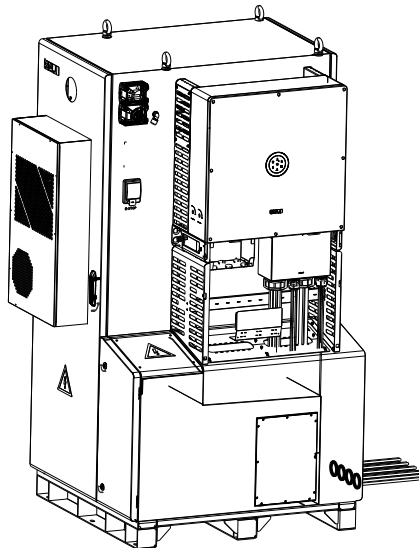

2. Loosen the lock screws on positive and negative connector.
3. Strip the insulation of the positive and negative cables with 8-10mm length.

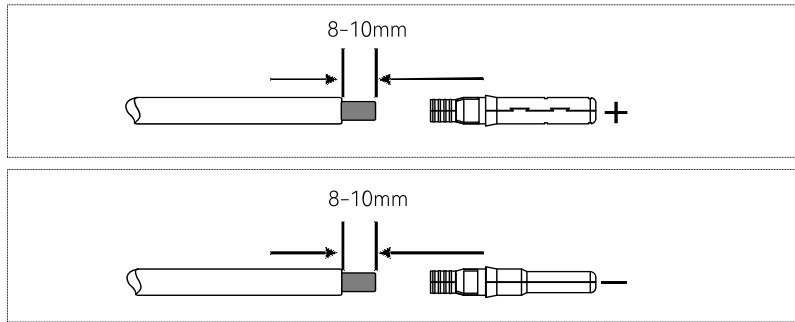

4. Assembly the positive and negative cables with corresponding crimping pliers.

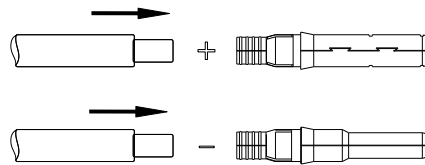

5. Insert the positive and negative cable into positive and negative connector. Gently pull the cables backward to ensure firm connection.

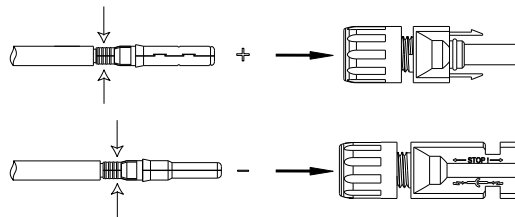

6. Fasten the lock screws on positive and negative connectors.

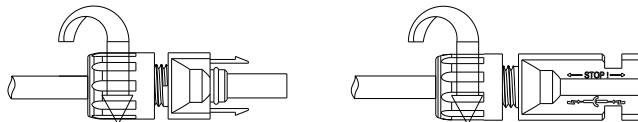

7. Make sure the DC switch is at OFF position.

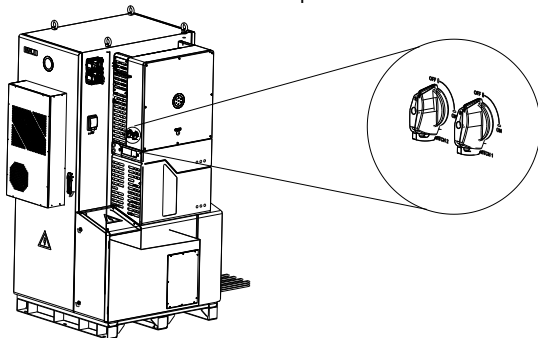

8. Connect the positive and negative connectors into positive and negative DC input terminals of the inverter, a “click” should be heard or felt when the contact cable assembly is seated correctly.

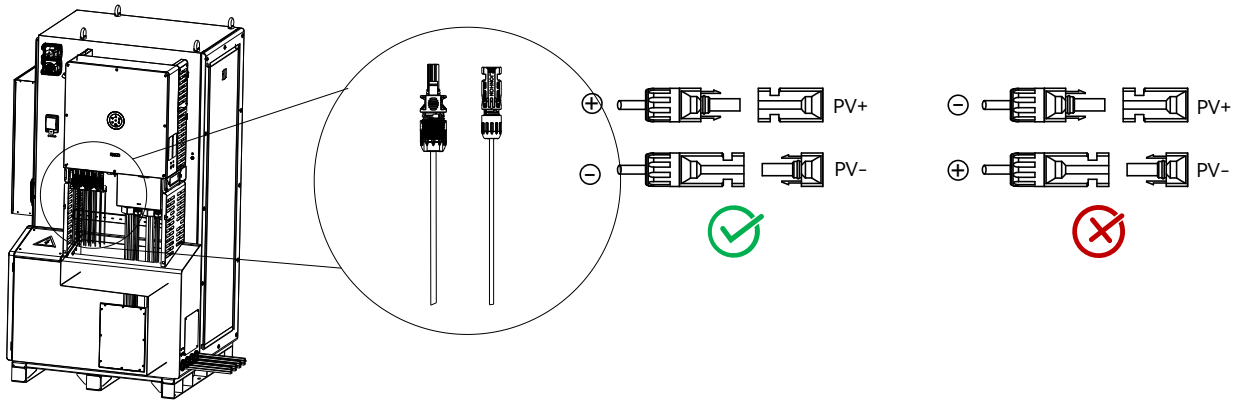

9. Install the PV cover on the PV port, secure it with screws.

7. Communication Module Installation

Plug in the communication module to 4G/WIFI port and secure the module by rotating the nut.

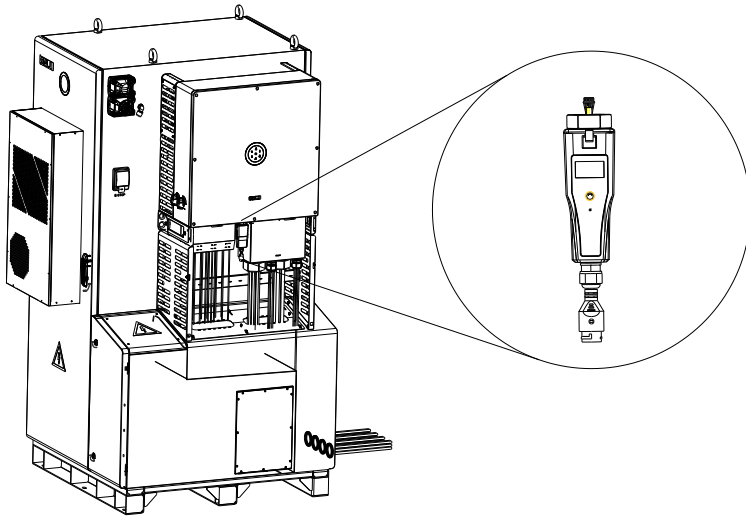

8. Install Decorative Panels

Reinstall the removed decorative panel onto the machine.

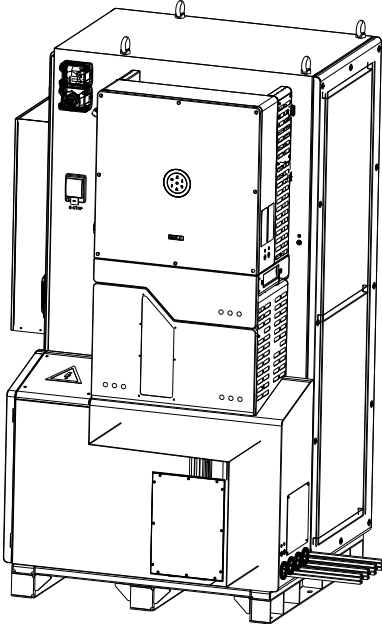

Installer: _____