



Anhui Sine New Energy Co.,Ltd

Address: No. 1 Hudong Road,Hefei Zhongmeng Electronic
& Information Park, Feixi,Hefei, Anhui, China

Tel: 0551-62865636

Email: info@sine-energy.com

Installation Guide for Module

Purpose of this guide

This guide contains information regarding the installation and safe handling of photovoltaic modules made by Anhui Sine New Energy Co., Ltd.

Anhui Sine New Energy Co., Ltd. hereafter is referred to as “**Sine Energy**”.

All instructions should be read and understood before installing the modules. The installation of modules should conform to all the safety precautions in this guide when installing the modules. The local standards should also be followed in such installations. If there are any questions, please contact our sales department for further assistance.

Before installing a photovoltaic system, the installer should be familiar with the mechanical and electrical requirements for such a system. Keep this guide in a safe place for future reference (maintenance).

The mechanical and electrical installation of modules should consult the corresponding laws and regulations, such as electrical method, building law.

Scope

PV modules are ideal for charging storage batteries used to power remote homes, recreational vehicles, boats, telecommunication systems and other electrical applications.

This manual contains important installation, maintenance and safety information. The word “module” as used in this manual refers to one or more PV modules.

“**Sine Energy**” modules are designed to fulfill the criteria of protection class II requirements according to IEC61730-part1.

The modules are qualified for protection class II: Hazardous voltage (IEC61730: higher than 50V DC; EN61730: higher than 120V), hazardous power applications (higher than 240W) where general contact access is anticipated (Modules qualified for safety through EN IEC61730-1 and -2).

Disclaimer of liability:

The installation techniques, handling and use of this product are beyond company control. Therefore, “**Sine Energy**” does not assume responsibility for loss, damage or expense resulting from improper installation, handling or misuse.

General Safety Information



Anhui Sine New Energy Co.,Ltd

Address: No. 1 Hudong Road,Hefei Zhongmeng Electronic
& Information Park, Feixi,Hefei, Anhui, China

Tel: 0551-62865636

Email: info@sine-energy.com

Ensure that the module is used only in applications for which it is suitable (see “Installing Modules”). All work on a PV system (installation, setup, maintenance) must be carried out only by appropriately qualified and authorized engineers.

The appropriate DIN standards, construction rules and safety instructions must be followed during installation.

Warning!

PV modules generate electricity as soon as they are exposed to the sunlight. One module generates the safety extra low volt level, but multiple modules connected in series (summing the voltage) or in parallel (summing the current) represent a danger. The following points must be noticed when handling the solar modules to avoid the risk of fire, sparking and fatal electric shock.

Do not use mirrors or other magnifiers to artificially concentrate sunlight on the modules!



Do not insert any electrically conducting materials into the plugs or sockets!



Do not insert any electrically conducting materials into the plugs sockets!

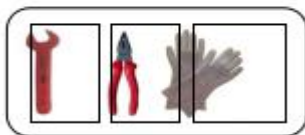

Make sure to use safety equipment (insulated tools, insulated gloves, etc.) when wiring.

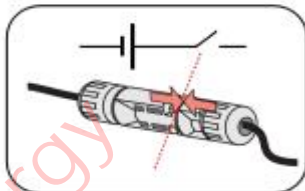

Make sure that we do the connection when the circuitry is cut off. Do not disconnect under load.

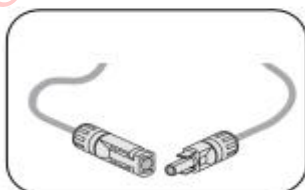

Guarantees the clean connectors has not been polluted, and the electrical connection and the mechanical joint is good, to avoid the generation of electric arc effectively.



Anhui Sine New Energy Co.,Ltd

Address: No. 1 Hudong Road,Hefei Zhongmeng Electronic & Information Park, Feixi,Hefei, Anhui, China

Tel: 0551-62865636

Email: info@sine-energy.com

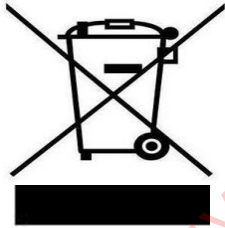

Meaning of crossed –out wheeled dustbin:Do not dispose of electrical appliances as unsorted municipal waste, use separate collection facilities.Contact your local government for information regarding the collection systems available.If electrical appliances are disposed of In landfills or dumps, hazardous substances can leak into the groundwater and get into the food chain, damaging

your health and well being.When replacing old appliances with new ones, the retailer is legally obligated to take back your old appliance for disposals at least free of charge.

Unpacking and Storing Modules:

Utmost attention is required when handling the modules. Below marks will be used for some caution items when unpacking, transporting, and storing the modules:



Do not strike and destroy the module.

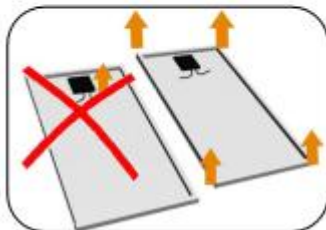

Carry modules with both hands. Do not use the connection socket as a handle;

Don't lacerate the frame during handling and installing.

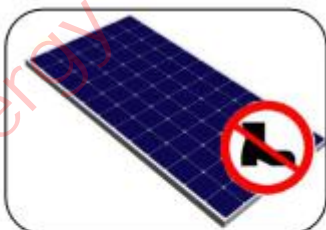

Do not stand on the module.

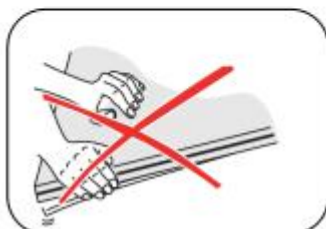

Do not twist the module.Do not twist the module.



Do not mark on the rear of the module using sharp objects.

The accessible PV module surface shall be smooth and free from sharp edges, burrs, etc.,

Installing Modules:

Please consult local laws and regulations before installing modules and abide by requirements on building fire protection.

System should be installed by qualified personnel only. The system involves electricity, and can be dangerous if the personnel are not familiar with the appropriate safety procedures.

The PV modules should be mounted in a location where they will receive maximum sunlight throughout the year. In the Northern Hemisphere, the modules should face south. And in the Southern Hemisphere, the modules should face north.

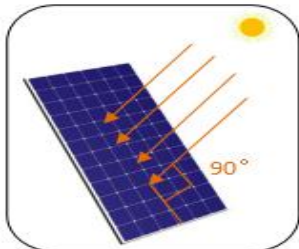

In order to achieve maximum annual yield, optimum orientation and tilt of PV modules is necessary. Sunlight shining vertically onto the PV module is the best condition to generate maximum power. Artificially concentrated sunlight shall not be directed on the module.



Make sure the module absorb sunlight without any shelter to produce the maximum output.

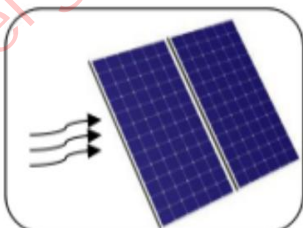

Keeping good ventilation conditions prevents the modules from getting hot which would reduce the output performance.

Anhui Sine New Energy Co.,Ltd

Address: No. 1 Hudong Road, Hefei Zhongmeng Electronic & Information Park, Feixi, Hefei, Anhui, China

Tel: 0551-62865636

Email: info@sine-energy.com

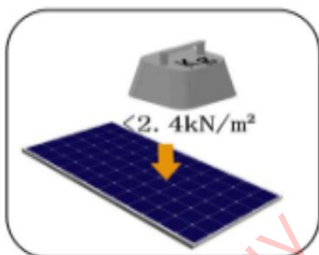

The maximum load on module must not exceed 2.4kN/m^2

Site-specific environment loads such as wind and snow should be taken into account to avoid exceeding the maximum.

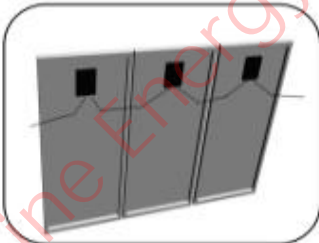

The voltage in series should not exceed the system voltage nominated by manufacturer. When designing the system, recommended the maximum number of modules in parallel should be no more than four while the maximum number of modules in series no more than fifteen.



The module must not be installed close to fire or Flammable materials.

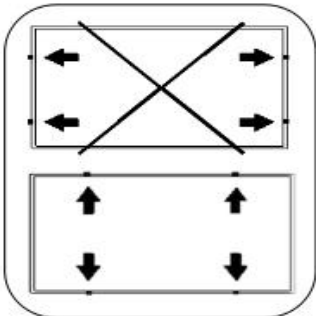

Each module should be fixed at least 8 points on long frame or short frame.

The modules are supported parallel to the surface of the building wall or roof. And the assembly is to be mounted over a fire resistant roof covering rated for module's application.

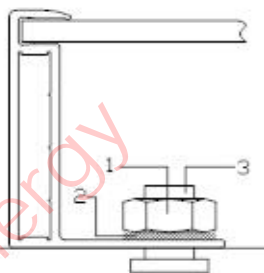

Use the existing installation holes instead of drilling additional holes for installation (Drilling holes shall against the reliability and warranty of the modules). The installation and attachment materials (nuts, bolts, etc) must be corrosion-resistant. Moment of force is $5\text{N}\cdot\text{m}$ for module mounting.

- 1 Stainless steel M8 nut
- 2 Stainless steel spring washer
- 3 Stainless steel M8 t-head bolt

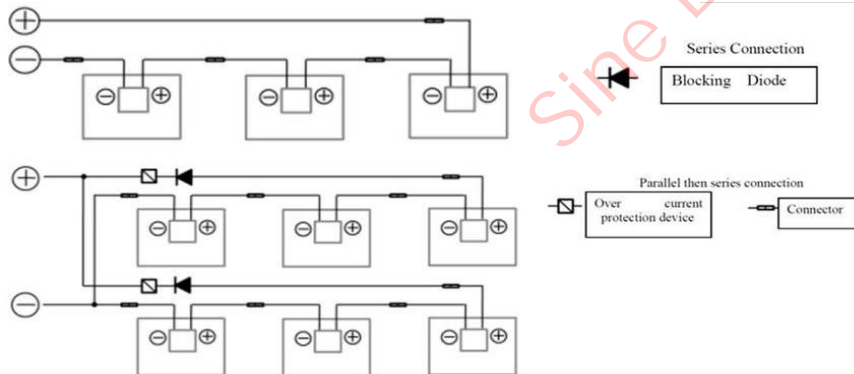

It is suggested to confirm according to the voltage and current actually used in the power station.

Grounding:

Although the modules are certified to Safety qualification, grounding is nevertheless to be used. The grounded connection must be made by a qualified electrician.

Connect module frames to each other using cables with cable lugs.

All the junctions on the conductive connection must be fixed. Soldering is not required.

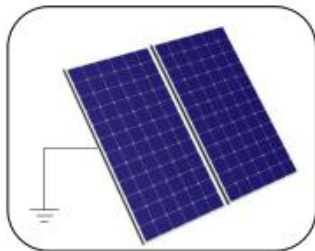

- The metallic frames must be grounded according to Article 250 of the U.S. NEC.
- Should provide appropriate engagement through the anodized layer.
- PV system should work with a reliable lightning protection system.

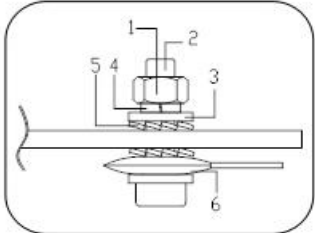

- 1 Stainless steel nut M4
- 2 stainless steel bolt M4×30
- 3 stainless steel flat washer M4
- 4 stainless steel spring washer M4
- 5 stainless steel serrated washer M4
- 6 stainless steel slotted washer M4

All ferrous metal in the conductive connection should specially treated, such as by anodization, spray-painting, galvanization. Stainless steel does not need to be treated.

This protection has been punctured by the grounding device to achieve sufficient connection.

Wiring

To ensure proper wiring, pay close attention to:

·Correct wiring scheme

When designing the system, avoid forming close loop to minimize risk of an indirect lightning strike.



Anhui Sine New Energy Co.,Ltd

Address: No. 1 Hudong Road,Hefei Zhongmeng Electronic
& Information Park, Feixi,Hefei, Anhui, China

Tel: 0551-62865636

Email: info@sine-energy.com

Check that wiring is correct before starting the generator. If the measured open circuit voltage (Voc) and short-circuit current (Isc) differ from the specifications, then there may be a wiring fault.

•Correct connection

The cross section area of cable and the capacity of connector must be selected to suit the maximum system short circuit current (The area of the cable mated with the connector is recommended to be 4~6 mm²), otherwise the cable and connector will be overheated under large current. Please note that the upper limit temperature of cable is 120°C and the connector is 100°C. The ambient temperature range of cable and connector is -40°C-90°C. The plug connector has its own polarity. Make sure that the connection is safe and tight. The plug connector should not receive outer stress. Connectors should only be used to connect the circuit, but never used to turn the circuit on or off.

•Use of suitable materials

Use cable extensions and plugs that are designed for outdoor applications. Ensure that they are in perfect electrical and mechanical condition. Only the cables with one conductor are used.

Ensure that all materials meet the requirements of the system maximum voltage, current, moisture, and temperature when they expose to sunlight.

Under normal conditions, a photovoltaic module is likely to produce more current and/or voltage than that reported under standard test conditions.

Accordingly, the values of Isc and Voc marked on this module should be multiplied by a factor of 1.25 when selecting electricity components voltage ratings, conductor capacities, fuse type, and type of control components connected to the PV output.

The maximum series Fuse rating is 20A. And the maximum reverse current is known as series Fuse rating multiplied by a factor of 1.35.

•Bypass Diodes

When modules in series are shaded partially, it may cause reverse voltage across cells or modules, this may cause undesirable heating to occur. The use of a diode to bypass the shaded area can minimize both heating and array current reduction.

All "Sine Energy" modules are equipped with factory installed bypass diodes. The factory installed diodes provide proper circuit protection for the system. Rating of bypass diodes: Current 10A; Voltage 50V

• Others

During installation, be sure to tie the cable from the junction box to the mounting substructure with nylon line, etc. to avoid direct contact of the cable with the back surface of the module.

Module mounting

Sine Energy's Limited Warranty for modules is based upon modules being mounted in accordance with following conditions.

1) Operating conditions

Install Sine Energy Solar Crystalline series modules in the following conditions:

- .Operating temperature: -40°C to +85°C
- . Storage temperature: -20°C to +50°C



Anhui Sine New Energy Co.,Ltd

Address: No. 1 Hudong Road,Hefei Zhongmeng Electronic
& Information Park, Feixi,Hefei, Anhui, China

Tel: 0551-62865636

Email: info@sine-energy.com

- . Humidity: below 85RH%
- . Altitude: $\leq 2000\text{m}$
- . Mechanical Load Pressure: 2400Pa (245 Kg/m²)

*Mechanical load bearing specifications of the module is based on **SN** Solar mounting methods. A professional system installer must be responsible for the mechanical load calculations based on the specific system design.

*The modules have been evaluated by TUV according to IEC61215 for a maximum positive design loading of below 2400Pa, and negative design loading 1600Pa,with 1.5 times safety factor.

2) Limited conditions

Installation environment with following conditions should be avoided.

- The installation area with extreme sand and dust damage.
- The installation position with extreme air pollution, chemical vapors, acid rain, and/or soot, etc.
- The installation place with extreme hail and snow damage.
- The installation location with extreme salt damage.

Checklists:

- All fastenings are tight, secure and free of corrosion.
- All cable connections are secure, tight, clean and free of corrosion.
- Cables are not damaged in any way.
- Verification of the grounding resistivity of metals.

Maintenance and Cleaning

Do not change the PV components (diode, junction box, plug connectors) that can be serviced by “**SN**” authorized distributor or dealer without voiding the warranty.

Given the module a sufficient tilt (at least 15°) to keep one self-clean effect in normal conditions (rainfall will have a self-cleaning effect). When heavy soiling happened on the module (which will result in output reductions), we use a gentle cleaning implement (such as a sponge) and water (from a hose) without clean agents to rinse the modules. Dried dirt must never be scraped or rubbed, scraping and rubbing module surface will cause micro-scratching. Periodic inspection must be done for the system.

Module Specifications

Please refer to the latest Module specifications for more details.



Anhui Sine New Energy Co.,Ltd

Address: No. 1 Hudong Road, Hefei Zhongmeng Electronic & Information Park, Feixi, Hefei, Anhui, China

Tel: 0551-62865636

Email: info@sine-energy.com

MODULE SPECIFICATIONS UNDER STC CONDITION

Model Type	Module Technology	Number Of Cells	Maximum Power (Pmax) [W] Tolerance \pm 5%	Open Circuit Voltage (Voc) [V] Tolerance \pm 5%	Maximum Power Voltage (Vmp) [V]	Short Circuit Current (Isc) [A] Tolerance \pm 5%	Maximum Power Current (Imp) [A]	Maximum Over Current Protection [A]
SNM460-144M	Mono crystalline	144	460	50.25	42.67	11.41	10.78	20 A
SNM455-144M	Mono crystalline	144	455	50.10	42.41	11.37	10.73	20 A
SNM450-144M	Mono crystalline	144	450	49.83	42.10	11.34	10.69	20 A
SNM445-144M	Mono crystalline	144	445	49.55	41.75	11.31	10.66	20 A
SNM440-144M	Mono crystalline	144	440	49.25	41.40	11.28	10.63	20 A
SNM435-144M	Mono crystalline	144	435	48.99	41.08	11.25	10.59	20 A
SNM430-144M	Mono crystalline	144	430	48.69	40.72	11.22	10.56	20 A
SNM425-144M	Mono crystalline	144	425	48.39	40.36	11.18	10.53	20 A
SNM420-144M	Mono crystalline	144	420	48.11	40.01	11.15	10.50	20 A
SNM380-120M	Mono crystalline	120	380	41.70	34.50	11.56	11.02	20 A
SNM375-120M	Mono crystalline	120	375	41.50	34.30	11.48	10.93	20 A
SNM370-120M	Mono crystalline	120	370	41.30	34.10	11.37	10.86	20 A
SNM365-120M	Mono crystalline	120	365	41.10	33.90	11.28	10.77	20 A
SNM360-120M	Mono crystalline	120	360	40.90	33.70	11.20	10.69	20 A
SNM355-120M	Mono crystalline	120	355	40.70	33.50	11.10	10.60	20 A
SNM350-120M	Mono crystalline	120	350	40.50	33.30	11.02	10.52	20 A

MODULE SPECIFICATIONS UNDER STC CONDITION

Model Type	Module Technology	Number Of Cells	Maximum Power (Pmax) [W] Tolerance \pm 5%	Open Circuit Voltage (Voc) [V] Tolerance \pm 5%	Maximum Power Voltage (Vmp) [V]	Short Circuit Current (Isc) [A] Tolerance \pm 5%	Maximum Power Current (Imp) [A]	Maximum Over Current Protection [A]
SN550-144M	Mono crystalline	144	550	49.83	41.33	13.79	13.30	20 A
SN545-144M	Mono crystalline	144	545	49.68	41.18	13.71	13.24	20 A
SN540-144M	Mono crystalline	144	540	49.53	41.03	13.63	13.17	20 A
SN535-144M	Mono crystalline	144	535	49.38	40.88	13.54	13.10	20 A
SN530-144M	Mono crystalline	144	530	49.23	40.73	13.46	13.02	20 A
SN525-144M	Mono crystalline	144	525	49.08	40.58	13.39	12.95	20 A
SN520-144M	Mono crystalline	144	520	48.95	40.43	13.35	12.86	20 A



Anhui Sine New Energy Co.,Ltd

Address: No. 1 Hudong Road, Hefei Zhongmeng Electronic & Information Park, Feixi, Hefei, Anhui, China

Tel: 0551-62865636

Email: info@sine-energy.com

SN515-144M	Mono crystalline	144	515	48.81	40.33	13.30	12.77	20 A
SN455-120M	Mono crystalline	120	455	41.32	34.42	13.75	13.22	20 A
SN450-120M	Mono crystalline	120	450	41.25	34.21	13.62	13.16	20 A
SN445-120M	Mono crystalline	120	445	41.10	34.06	13.52	13.07	20 A
SN440-120M	Mono crystalline	120	440	40.95	33.91	13.41	12.98	20 A
SN435-120M	Mono crystalline	120	435	40.82	33.85	13.31	12.85	20 A
SN430-120M	Mono crystalline	120	430	40.70	33.86	13.20	12.70	20 A
SN500-132M	Mono crystalline	132	500	45.41	38.11	13.58	13.12	20 A
SN495-132M	Mono crystalline	132	495	45.28	37.95	13.47	13.04	20 A
SN490-132M	Mono crystalline	132	490	45.13	37.89	13.36	12.93	20 A
SN485-132M	Mono crystalline	132	485	45.02	37.77	13.25	12.84	20 A
SN480-132M	Mono crystalline	132	480	44.91	37.65	13.16	12.75	20 A
SN475-132M	Mono crystalline	132	475	44.80	37.52	13.07	12.66	20 A
SN410-108M	Mono crystalline	108	410	37.16	31.01	13.67	13.22	20 A
SN405-108M	Mono crystalline	108	405	37.12	30.98	13.60	13.07	20 A
SN400-108M	Mono crystalline	108	400	37.08	30.92	13.53	12.94	20 A
SN395-108M	Mono crystalline	108	395	37.04	30.86	13.47	12.80	20 A
SN390-108M	Mono crystalline	108	390	37.00	30.80	13.41	12.66	20 A

MODULE SPECIFICATIONS UNDER STC CONDITION

Model Type	Module Technology	Number Of Cells	Maximum Power (Pmax) [W] Tolerance ± 5%	Open Circuit Voltage (Voc) [V] Tolerance ± 5%	Maximum Power Voltage (Vmp) [V]	Short Circuit Current (Isc) [A] Tolerance ± 5%	Maximum Power Current (Imp) [A]	Maximum Over Current Protection [A]
SN260-60P	Poly crystalline	60	260	38.06	30.80	9.08	8.44	20 A
SN265-60P	Poly crystalline	60	265	38.18	31.03	9.12	8.54	20 A
SN270-60P	Poly crystalline	60	270	38.30	31.29	9.16	8.63	20 A
SN275-60P	Poly crystalline	60	275	38.46	31.54	9.22	8.72	20 A
SN280-60P	Poly crystalline	60	280	38.85	31.88	9.33	8.78	20 A
SN285-60P	Poly crystalline	60	285	39.01	31.96	9.44	8.92	20 A
SN290-60P	Poly crystalline	60	290	39.20	32.20	9.54	9.01	20 A
SN295-60P	Poly crystalline	60	295	39.36	32.49	9.62	9.08	20 A
SN300-60P	Poly crystalline	60	300	39.48	32.75	9.71	9.16	20 A
SN310-72P	Poly crystalline	72	310	45.51	37.35	8.97	8.30	20 A
SN315-72P	Poly crystalline	72	315	45.69	37.62	8.99	8.38	20 A
SN320-72P	Poly crystalline	72	320	45.86	37.81	9.02	8.46	20 A



Anhui Sine New Energy Co.,Ltd

Address: No. 1 Hudong Road, Hefei Zhongmeng Electronic & Information Park, Feixi, Hefei, Anhui, China

Tel: 0551-62865636

Email: info@sine-energy.com

SN325-72P	Poly crystalline	72	325	46.04	38.06	9.05	8.54	20 A
SN330-72P	Poly crystalline	72	330	46.36	38.33	9.10	8.61	20 A
SN335-72P	Poly crystalline	72	335	46.43	38.62	9.19	8.68	20 A
SN340-72P	Poly crystalline	72	340	46.73	38.91	9.26	8.74	20 A
SN345-72P	Poly crystalline	72	345	46.98	39.18	9.32	8.81	20 A
SN350-72P	Poly crystalline	72	350	47.23	39.45	9.38	8.87	20 A
SN355-72P	Poly crystalline	72	355	47.38	39.75	9.42	8.93	20 A
SN360-72P	Poly crystalline	72	360	47.53	39.96	9.49	9.01	20 A
SN365-72P	Poly crystalline	72	365	47.68	40.15	9.53	9.09	20 A

MODULE SPECIFICATIONS UNDER STC CONDITION

Model Type	Module Technology	Number Of Cells	Maximum Power (Pmax) [W] Tolerance ± 5%	Open Circuit Voltage (Voc) [V] Tolerance ± 5%	Maximum Power Voltage (Vmp) [V]	Short Circuit Current (Isc) [A] Tolerance ± 5%	Maximum Power Current (Imp) [A]	Maximum Over Current Protection [A]
SNN420-144M	Mono crystalline	144	420	49.91	41.02	10.68	10.24	20 A
SNN415-144M	Mono crystalline	144	415	49.76	40.84	10.60	10.16	20 A
SNN410-144M	Mono crystalline	144	410	49.68	40.52	10.53	10.12	20 A
SNN405-144M	Mono crystalline	144	405	49.58	40.29	10.49	10.06	20 A
SNN400-144M	Mono crystalline	144	400	49.39	40.07	10.42	9.99	20 A
SNN395-144M	Mono crystalline	144	395	49.18	39.86	10.38	9.91	20 A
SNN390-144M	Mono crystalline	144	390	49.04	39.67	10.34	9.83	20 A
SNN385-144M	Mono crystalline	144	385	48.92	39.49	10.30	9.75	20 A
SNN380-144M	Mono crystalline	144	380	48.80	39.30	10.26	9.67	20 A
SNN375-144M	Mono crystalline	144	375	48.68	39.10	10.22	9.59	20 A
SNN350-120M	Mono crystalline	120	350	41.32	35.32	10.36	9.91	20 A
SNN345-120M	Mono crystalline	120	345	41.25	34.92	10.32	9.88	20 A
SNN340-120M	Mono crystalline	120	340	40.98	34.52	10.28	9.85	20 A
SNN335-120M	Mono crystalline	120	335	40.71	34.16	10.24	9.81	20 A
SNN330-120M	Mono crystalline	120	330	40.44	33.80	10.20	9.76	20 A
SNN325-120M	Mono crystalline	120	325	40.13	33.62	10.16	9.67	20 A
SNN320-120M	Mono crystalline	120	320	40.02	33.40	10.12	9.58	20 A
SNN315-120M	Mono crystalline	120	315	39.90	33.19	10.08	9.49	20 A